

LABORATORY SESSION 8

SQUIRREL CAGE INDUCTION MOTOR CHARACTERISTICS



CAUTION: High voltages are present in this Laboratory Experiment! Do not make any connections with the power on! The power must be turned off before the circuit is modified.

PURPOSE

The purpose of this experiment is to obtain the performance characteristics of a three-phase squirrel cage induction motor and to demonstrate the forward and reverse motor control using PLC. Become familiar with the use of a variable frequency AC drive.

DISCUSSION

Three-phase induction motors are by far the most widely used in industry. They constitute about 80% of the total number of motors used in industry. Three-phase induction motors are popular because they are more economical, last longer, and require less maintenance than other types of motors. The stator is composed of laminations of high-grade sheet steel. A three-phase winding is put in slots cut on the inner surface of the stator frame. The stator windings can be either wye- or delta-connected. The simplest and most widely-used rotor for induction motors is the squirrel cage rotor. A squirrel cage rotor consists of bare aluminum bars that are connected at their terminals to shorted end rings. The rotor bars are not parallel to the rotor axis but are set at a slight skew. This reduces mechanical vibrations, so the motor is less noisy.

The operation of three-phase induction motors is based on the generation of a revolving field, the transformer action, and the alignment of the magnetic field axis. When balanced three-phase currents are injected in the stator windings, a rotating magnetic field is created in the stator. To see a demonstration of the rotating magnetic field type **rotfield** at the MATLAB prompt. The speed of the stator revolving field is known as synchronous speed and the speed in rpm is given by

$$n_s = \frac{120 f_s}{p} \quad (8.1)$$

Where f_s is the supply voltage frequency and p is the number of poles, resulting from the stator winding design.

This revolving field cuts the rotor bars and generates voltages in them by electromagnetic induction. Because rotor bars are short-circuited, the induced voltages circulate currents in the rotor. The circulating rotor currents then produce their own revolving fields. The magnetic fields of the stator and rotor try to align their magnetic axes - a natural phenomenon - and in so doing, a torque is developed and the rotor will come up to speed. The rotor cannot revolve with the same speed as the stator revolving-field. Because if the rotor could be running at synchronous speed there would be no induced voltage in the rotor, no rotor current and no torque to overcome the rotational losses. The difference between the synchronous speed of the stator field (n_s) and the actual rotor speed (n_r) expressed to the base of synchronous speed is called the motor slip, i.e.

$$s = \frac{n_s - n_r}{n_s} \quad (8.2)$$

From (8.2) rotor speed can be expressed as

$$n_r = (1 - s)n_s \quad (8.3)$$

Since the induced voltage in the rotor is proportional to the relative motion ($n_s - n_r$), the rotor voltage frequency is given by

$$f_r = s f_s \quad (8.4)$$

Which sets up a rotor field traveling with speed $s n_s$ rpm with respect to the rotor. The speed of rotor field with respect to the stationary stator is the sum of this rotation and the rotor speed

$$s n_s + n_r = s n_s + (1 - s)n_s = n_s \quad (8.5)$$

The stator and rotor fields are therefore stationary with respect to each other, and a steady torque is produced, and rotation is maintained.

When rotor is stationary, $s = 1$ and the rotor frequency is the same as the stator frequency. This is similar to the transformer action, and the rotor emf at standstill E_2 , is proportional to the turns ratio. At any other speed the rotor emf is given by sE_2 . Also, showing the rotor reactance per phase at standstill by X_2 , when rotor is running its reactance is sX_2 . In the squirrel cage rotor there is no access to the rotor circuit and the rotor resistance is constant. The torque-speed characteristic of an induction motor is directly related to the resistance and reactance of the rotor. Hence, different torque-speed characteristics may be obtained by designing rotor circuits with different ratios of rotor resistance to rotor reactance. In some special designs the rotor may have double squirrel windings, each with a different resistance. This construction gives higher starting torque, lower starting current, and higher full-load power factor. The National Electrical Manufacturers Association (NEMA) has developed a code by which a letter (A, B, C, or D) designates a particular class of motors with specific characteristics.

The analysis of the 3-phase induction motor is simplified by means of the per phase equivalent circuits. The per-phase equivalent circuit is shown in Figure 8.1 and is similar to the equivalent circuit of a transformer. The difference is that a variable resistance representing the mechanical load has been added. The resistance $R_2'(1-s)/s$ represents the gross mechanical load, including rotational losses. Note that the equivalent load resistance plus the rotor resistance is simply R_2'/s .

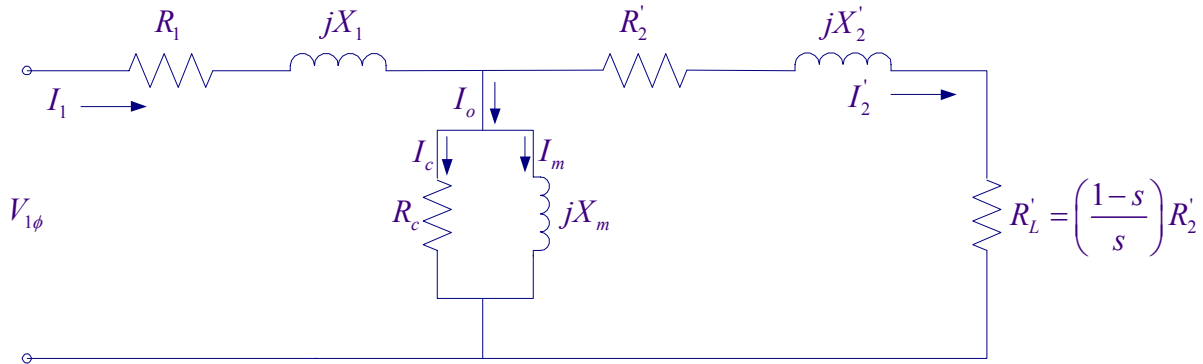

Figure 8.1 The per phase equivalent circuit of a three-phase induction motor

The gross mechanical power or internal power is

$$P_m = 3 \frac{(1-s)}{s} R_2' I_2'^2 \quad (8.6)$$

and the power transferred to rotor or power across air-gap is

$$P_{ag} = 3 \frac{R_2'}{s} I_2'^2 \quad (8.7)$$

and the internal torque is

$$T = \frac{P_m}{\omega_r} = \frac{P_{ag}}{\omega_s} = 3 \frac{R_2'}{s\omega_s} I_2'^2 \quad (8.8)$$

The referred rotor current can be computed from the above equivalent circuit and thus the torque-slip relation can be obtained in terms of the circuit parameters. From this expression the slip at maximum torque and/or pullout torque can be computed. It can also be shown that, for a certain range of rotor resistance, the starting torque of the motor is proportional to the rotor resistance. The total input power to the motor is given by

$$P_i = 3V_{1\phi} I_1 \cos \theta = \sqrt{3} V_L I_1 \cos \theta \quad (8.9)$$

Where V_L is the supply line-to-line voltage, I_1 is the stator line current, and $\cos \theta$ is the motor power factor.

Three-phase power measurement - A single wattmeter can be used to measure the average power per phase of a three-phase balanced load if a neutral is available. The two wattmeters method is the most commonly used method for three-phase power measurements. The algebraic sum of the two-wattmeter readings equals the total average power absorbed by the load, regardless of whether it is wye- or delta-connected, balanced or unbalanced. When a neutral is not available. Consider two wattmeters connected as in Figure 8.2 to measure the power supplied to a balanced Y-connected load.

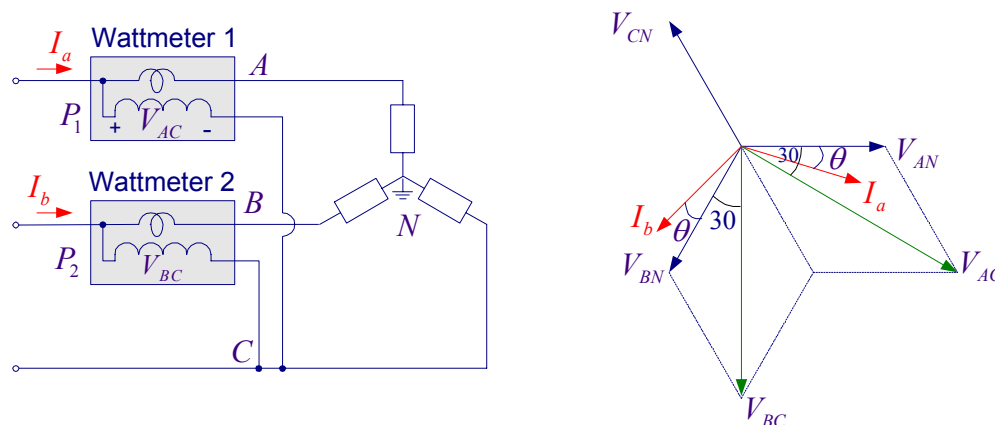

Figure 8.2 Two-wattmeter method for measuring three-phase power

Assume the source phase-sequence is abc and the load impedance is $Z = |Z| \angle \theta$. The wattmeter reads the product of the voltage across its potential coil times current in its current coil times the cosine of the phase angle between them. For a balanced load, if θ is the angle between the line current and the phase voltage as shown in Figure 8.2 (b), then for connection depicted in Figure 8.2(a), the wattmeter readings are:

$$P_1 = V_{AC} I_a \cos(30^\circ - \theta) = V_L I_1 \cos(30^\circ - \theta) = V_L I_1 \left(\frac{\sqrt{3}}{2} \cos \theta + 0.5 \sin \theta \right) \quad (8.10)$$

$$P_2 = V_{BC} I_b \cos(30^\circ + \theta) = V_L I_1 \cos(30^\circ + \theta) = V_L I_1 \left(\frac{\sqrt{3}}{2} \cos \theta - 0.5 \sin \theta \right)$$

The sum of the two wattmeters is

$$P_1 + P_2 = \sqrt{3} V_L I_1 \cos \theta \quad (8.11)$$

This indeed is the three-phase power in a balanced system therefore if the above two wattmeters are properly connected to measure the power input to a three-phase induction motor, the total power input is given by

$$P_i = P_1 + P_2 \quad (8.12)$$

When power factor is less than 0.5, i.e. when $\theta > 60^\circ$, P_2 will indicate negative. From (8.11) the power factor can be computed.

$$pf = \cos \theta = \frac{P_i}{\sqrt{3} V_L I_1} \quad (8.13)$$

Or in (8.10) subtracting P_2 from P_1

$$P_1 - P_2 = V_L I_1 \sin \theta \quad (8.14)$$

From (8.11) and (8.14)

$$pf = \cos \theta = \cos \left[\tan^{-1} \left(\sqrt{3} \frac{P_1 - P_2}{P_1 + P_2} \right) \right] \quad (8.15)$$

The motor power factor depends on the operating load. At no-load referred rotor current is very small and the stator current is mainly a magnetizing component I_m and a small component due

to stator iron loss I_c , thus the no-load power factor is very small, but as motor is loaded the power factor will improve.

The input power is given by (8.12). The output power is computed from the measurement of the dynamometer pull as follows:

$$T_o = \text{pull (Kg)} \times 9.81 \times \text{Arm radius (0.305 m)} \quad \text{N-m} \quad (8.16)$$

$$P_o = \omega_r T_o \quad \text{Watts} \quad (8.17)$$

Where, ω_r is the rotor speed in Rad/second given by, $\omega_r = \frac{2\pi n_r}{60}$ and n_r is the speed in RPM.

The motor efficiency is given by

$$\eta = \frac{P_o}{P_i} \times 100 \quad (8.18)$$

2. Reversing direction of rotation

In order to reverse the direction of rotation of an induction motor it is necessary to reverse the direction of the stator revolving field. This is done by simply interchanging two phases of the stator. A motor can be stopped by means of plugging. In this procedure when the motor is running two phases are interchanged. When the motor approaches zero speed the supply voltage is disconnected.

3. Variable Speed Drive

Induction motors are normally designed to work with a small value of slip (generally less than 5 percent) at full-load, and the deviation of the rotor speed from the synchronous speed is therefore small. There are certain applications, however, which require substantial variation of the rotor speed. The motor speed can conveniently be controlled by means of the variable frequency solid-state drives. Frequency-controlled induction motors are now comparable in cost with voltage-controlled dc motors for variable speed drives; the higher cost of the electronic controller is offset by the lower cost of the motor. Induction motors require little maintenance, and are better suited than dc motors to operation in hazardous or dusty environments.

Today, there is a relatively simple and economical way to convert 60 Hertz to a pseudo frequency that varies from almost zero Hz to at least 90 Hz. The actual waveform is not a sinusoidal wave, but is actually a very high frequency DC pulse whose width varies over the period of one-half of the cycle. The high inductance of the motor smooths out this waveform and allows the motor to function satisfactorily. Many schemes are used for producing a variable frequency supply.

The most commonly used adjustable speed motor drive technology is based upon the Pulse Width Modulation (PWM) inverter in which the three-phase 60 Hz AC line voltage is first rectified by a full-wave or a diode bridge rectifier and LC filter to form a single DC supply. Then solid-state transistors selectively fire as shown in Figure 8.3 and cause the waveform as shown in Figure 8.4 to be created. The output voltage is controlled by varying the on-off periods so that the on periods (pulse width) are longest at the peak of the wave. Figure 8.4 illustrates that by varying the width of the pulse the magnitude of the effective voltage can be varied. This variation over time can cause the output voltage to resemble a sine wave for each phase. The

illustration is analytical since the number of pulses per second will be well over 5000. This will reduce the ripple in the motor currents and thus reducing the ripple in the electromagnetic torque.

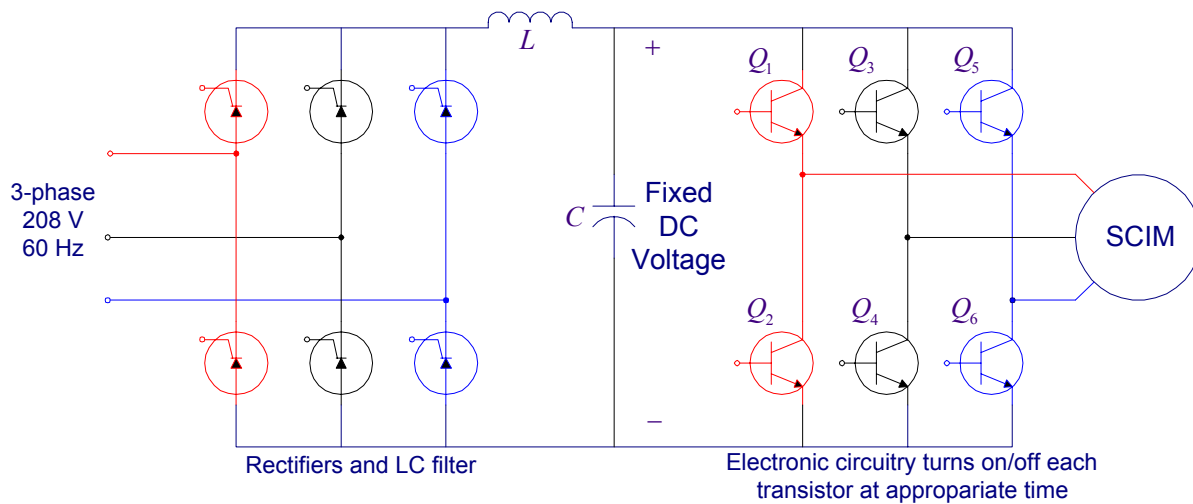

Figure 8.3 Basic rectifiers and PWM circuit diagram

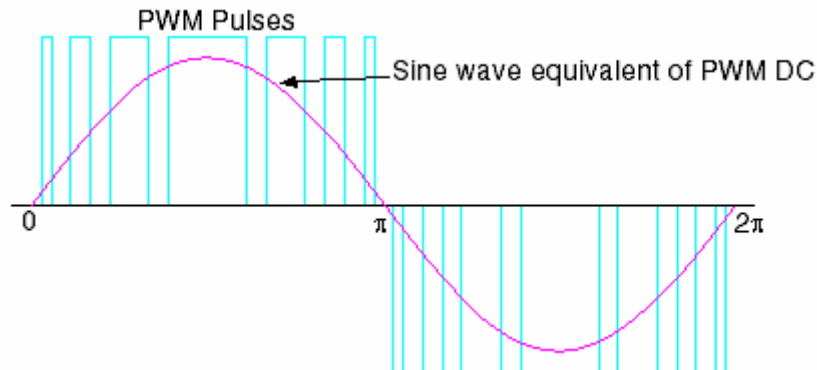

Figure 8.4 PWM waveform and its pseudo sine wave

PROCEDURE

1. PERFORMANCE CHARACTERISTICS

Check out the Fluke Power Quality Analyzer from the Technical Support Center.

Connect the induction motor to the 208V, three-phase supply as shown in Figure 8.5. Connect the red-shielded test lead (you may use ordinary lead) from the Power Quality Analyzer input 1 to the black terminal of the three-phase supply and a black lead from the COM terminal to the blue terminal of the three-phase supply. This will provide V_{B-Blue} voltage for the wattmeter.

Connect the Current Probe to the meter input 2 and clamp the Current Probe around the lead connecting the supply black terminal to the motor black terminal. Be sure that the arrow marked on the jaw of the Current Probe points toward the direction of current (supply to load). This will

provide the current I_b for the wattmeter. The real power recorded with this connection is designated as P_1 . Same meter is to be used to measure P_2 by moving the lead coming from input 1 and the current probe to the red phase and keeping the black test lead (COM) attached to the blue phase. To measure voltage and current open the main menu and select VOLTS/AMPS/HERTZ, and to measure Watt open the main menu and select POWER.

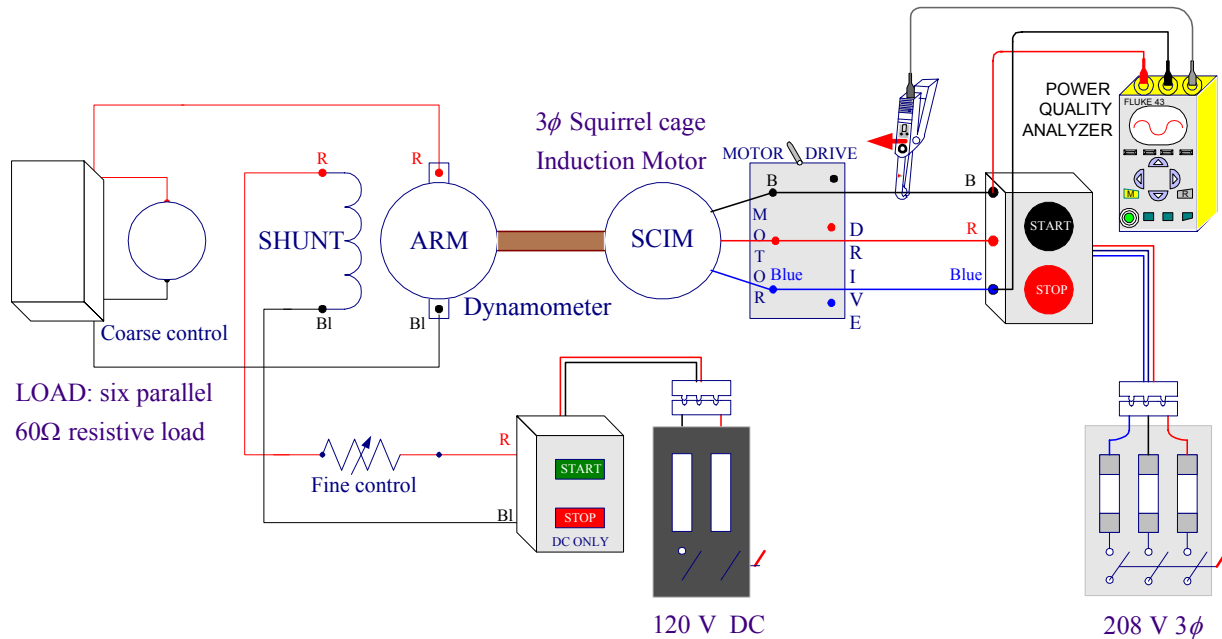

Figure 8.5 Circuit connections for induction motor and dynamometer

The induction motor is to be loaded by means of the dynamometer. Connect the dynamometer as a separately-excited dc generator as shown in Figure 8.5.

Zero the dynamometer scale. Start the induction motor. With the dynamometer on no-load and its field winding open (dc supply off) record the following data for the motor in Table 1: input line-to-line voltage, stator current I_1 , real power reading P_1 , motor speed and the dynamometer pull. Move the red test lead (Coming from input 1) and the Current Probe to the red phase (keep the black test lead (COM) attached to the blue phase). Be sure that the arrow marked on the jaw of the Current Probe points toward the direction of current (supply to load). This will provide V_{R-Blue} and the current I_{Red} for the wattmeter. Measure the real power and record it in Table I as P_2 .

At no-load, the motor power factor is low, if $\theta > 60^\circ$ according to (8.10), one wattmeter (P_2) will read negative. When the motor power factor is 0.5, ($\theta = 60^\circ$), P_2 will read zero and P_1 will indicate the total power taken by the motor. As the motor is loaded more, its power factor will become greater than 0.5 and both wattmeter readings will be positive.

Using the load resistor for coarse adjustments and the dynamometer field rheostat for fine adjustment, load the motor in step until it draws the full-load current. Repeat the above

procedure and at each step record the phase current I_1 , the real power measurements P_1 and P_2 , motor speed and dynamometer pull in Table I. Record the synchronous speed as given by (8.1).

$$n_s = \underline{\hspace{10em}}$$

TABLE I Data for determination of SCIM characteristics

Measured Data						Calculated Data					
V_{L-L} V	I_1 Amps	P_1 Watts	P_2 Watts	n_r RPM	Pull Kg	$P_i = P_1 + P_2$ Watts	T_o N-m	$P_o = \omega T$ Watts	$s = \frac{n_s - n_r}{n_s}$	pf (8.15)	η %

Stop the motor, and disconnect it from the 208V. Evaluate the calculated data and enter in Table I.

Use **ee340lab8** function as explained in the Appendix I to check your computed data and obtain the required plots.

2. FORWARD AND REVERSE MOTOR CONTROL CIRCUIT

In many controller applications the motor must be operable in both forward and reverse directions. Interchanging two phases of the stator connections to the three-phase supply will reverse the stator revolving field and the direction of rotation of the rotor. The requirement is that the motor be able to start and stop in either the forward or reverse direction and that the stop pushbutton be pressed in order to change from forward to reverse or from reverse to forward. Interlock must be provided so that both starters cannot be energized at the same time.

The ladder logic shown in Figure 8.6 provides start and stop in the forward direction and in the reverse direction. Only one stop pushbutton is used to stop the motor, regardless of the direction in which it is running. The normally closed contact C0 in the third rung will be opened whenever OUTPUT_C0 in the second rung is energized, thus preventing OUTPUT_C1 in the third rung from being energized at the same time. Similarly, the normally closed contact C1 in the second rung will be opened whenever OUTPUT_C1 in the third rung is energized, thus preventing OUTPUT_C0 in the second rung from being energized at the same time.

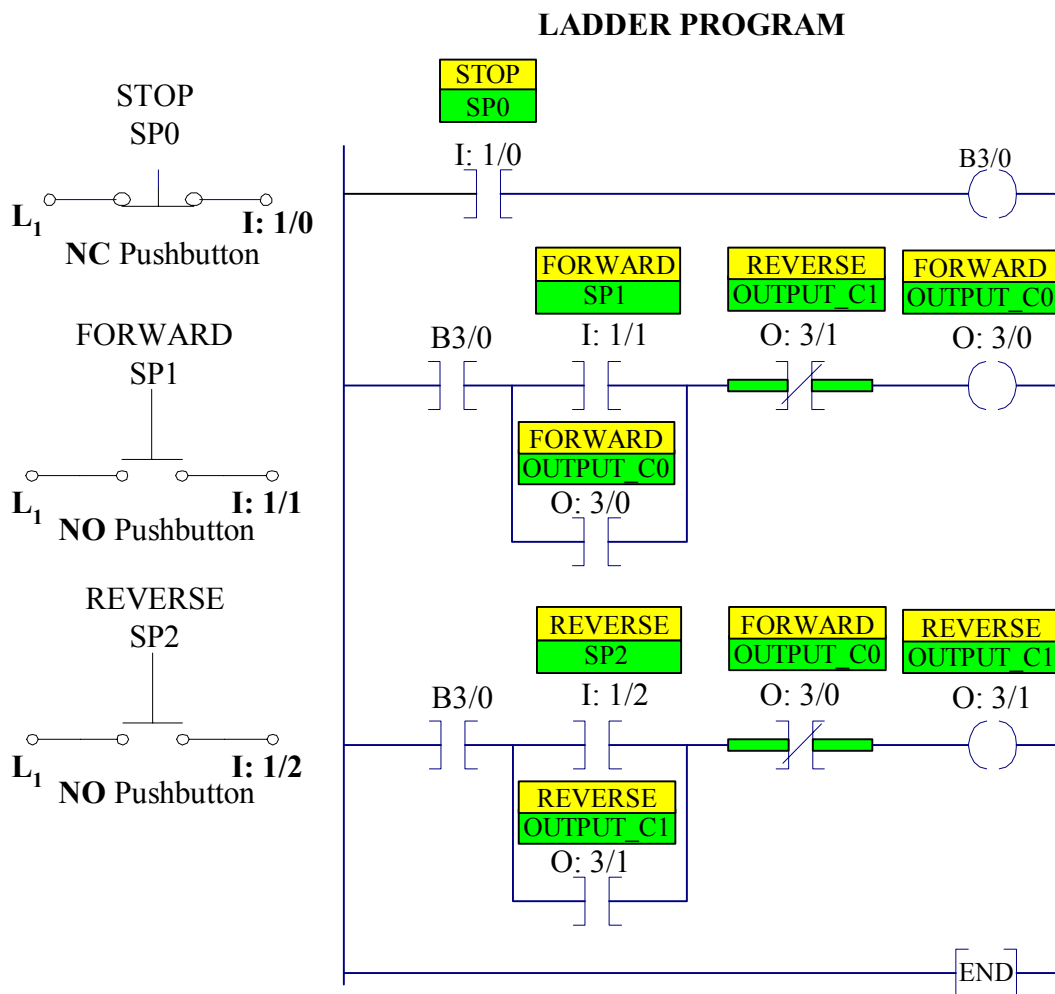

Figure 8.6 Ladder diagram for forward and reverse motor control

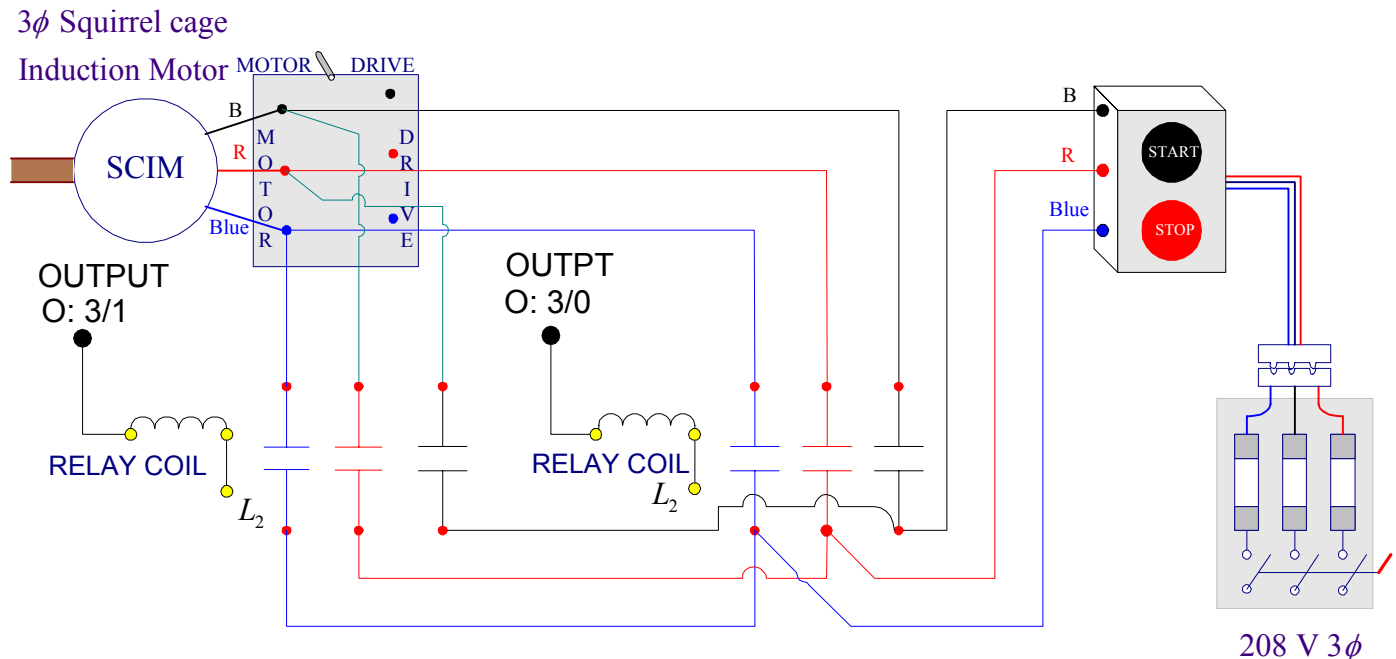

Figure 8.7 Circuit connections for forward and reverse motor control.

Program the ladder diagram shown in Figure 8.6 using RSLogix 500 software (refer to Laboratory Session 1 section 2.3 EDITING LADDER LOGIC). Connect the input circuit using three pushbuttons. Disconnect the dynamometer. Use the three-phase contactors C0 and C1 to connect the induction motor to the 208 V, three-phase supply. Connect the contactor yellow terminals to the related output addresses as shown in Figure 8.7. After I/O circuits and your ladder logic program have been checked by the instructor turn on the Processor Main Power. Follow the procedure in part 2.4 and 2.5 in Experiment # 1 to download the program to SLC-500 and demonstrate its operation in Test and run mode.

3. Variable Speed Drive

For a description of the MagneTex IntelliPac 100 Digital Operator Display refer to Appendix II. For more information check out the IntelliPac 100 Technical Manual.

Connect the three-phase 208 V supply to the AC Drive terminals and turn the switch to the DRIVE position. Turn on input power to the IntelliPac 100. The digital display will indicate the FREF (frequency reference) setting with the operator display status flashing 6.0. Go through the following steps while the motor is running:

- Press the **DSPL** key until the **FREF** is illuminated, if the frequency displayed is not 60 Hz press \wedge or \vee key until Digital Operator display reads 60 Hz and press **ENTER** key to keep the setting. Note the input frequency and measure the motor speed.
- Press the **DSPL** key until the **FMAX** is illuminated, press \wedge key until Digital Operator display reads 85 Hz. Press the **ENTER** key. Press the **DSPL** key until **FREF** is illuminated, increase the

frequency to a higher value (say 80 Hz), press the **ENTER** key. Note the frequency and measure the motor speed.

- Press the **DSPL** key until **FREF** is illuminated decrease the frequency to a lower value (say 40 Hz), press the **ENTER** key. Note the frequency and measure the motor speed.
- Press **DSPL** until **F/R** (FWD/REV selection) is illuminated, press \wedge or \vee to display **rEU** for reverse and press **ENTER** and then press **RUN**. Note how the motor will decelerate and run in the reverse direction. Reset all the functions to their original setting and press **STOP** to stop the motor.

There are many factory settings for all the parameters on the drive. Modifications include changing display, acceleration, deceleration, etc. Following are examples of two methods for setting the acceleration time (**n20**). The first example shows how to utilize the ACC function LED, and the second example shows how to access constant **n20** through the **PRGM** function LED when the drive is stopped.

Example 1: Using ACC LED

- | | <u>Display</u> |
|--|----------------|
| • Press the DSPL key until the ACC led is illuminated. | 10.0 |
| • To set the acceleration time to 5 seconds, press the \vee key until the Operator Digital display reads 5.0 | 5.0 |
| • Press the ENTER key. | 5.0 |
| • Press RUN and observe how the motor accelerates to the running condition. Stop the motor. | |

Example 2: Using PRGM LED

- | | |
|---|------|
| • Press DSPL key until the PRGM LED is illuminated. | n01 |
| • Press the \wedge key to access constant n20 . | n20 |
| • Press the ENTER . The current set value is displayed. | 5.0 |
| To set the acceleration time to 15 seconds, press \wedge key until Digital Operator display reads 15.0. | 15.0 |
| • Press the ENTER key. | n20 |
| • Press the DSPL key until the FREF LED is illuminated. | 60.0 |
| • Press RUN and observe how the motor accelerates to the running condition. Stop the motor. | |
| • Set the acceleration to the default setting (10.0). | |

REPORT REQUIREMENTS

1. Using Equations (8.13)-(8.18) calculate the load torque, power output, power input, power factor and efficiency of the induction motor from measured data at each loading. Show sample calculations. Power factor can be computed either by (8.13) or (8.15).
2. Plot on one graph curves of stator current and torque versus speed. On a second graph, plot curves of power factor and efficiency versus speed. Explain the theoretical basis for the shape of all the curves. Explain the reason why the power factor is low at no-load.

3. Outline the step-by-step sequence of operation for the forward and reverse motor control circuit. Interlocking has been provided by means of two NC contacts so that both starters cannot be started at the same time. What would happen if this were not included in the ladder logic diagram?
4. One of the reasons for the popularity of the dc motor in the industry in the past has been the ease with which the speed of a dc motor can be changed. Is a wide range of speed control possible with a squirrel cage induction motor driven by a constant frequency supply? State how the starting and speed control of induction motors are achieved and why induction motors have gained overwhelming popularity in industry and applications requiring variable speed operation.
5. Briefly discuss the observation made in part 3 using the MagneTex AC drive with some concluding remark.

Appendix I

In MATLAB, from **File/New/M-File**, open the MATLAB Editor. Enter the data for the squirrel cage induction motor in the $n \times 6$ matrix named `IMinput`. Each column represents a variable that must be entered in the order shown below. Use the function named **ee340lab8** as indicated below to obtain the calculated data and the required plots. The function **ee340lab8** has been added to the MATLAB available on the MSOE network. If you have your own MATLAB student version you may download this function to your Laptop.

```
%           V       I1       P1       P2       n       Pull
IMinput = [
                                                    ];

ee340lab8(IMinput)
```

Appendix II

InteliPac 100 Digital Operator Display

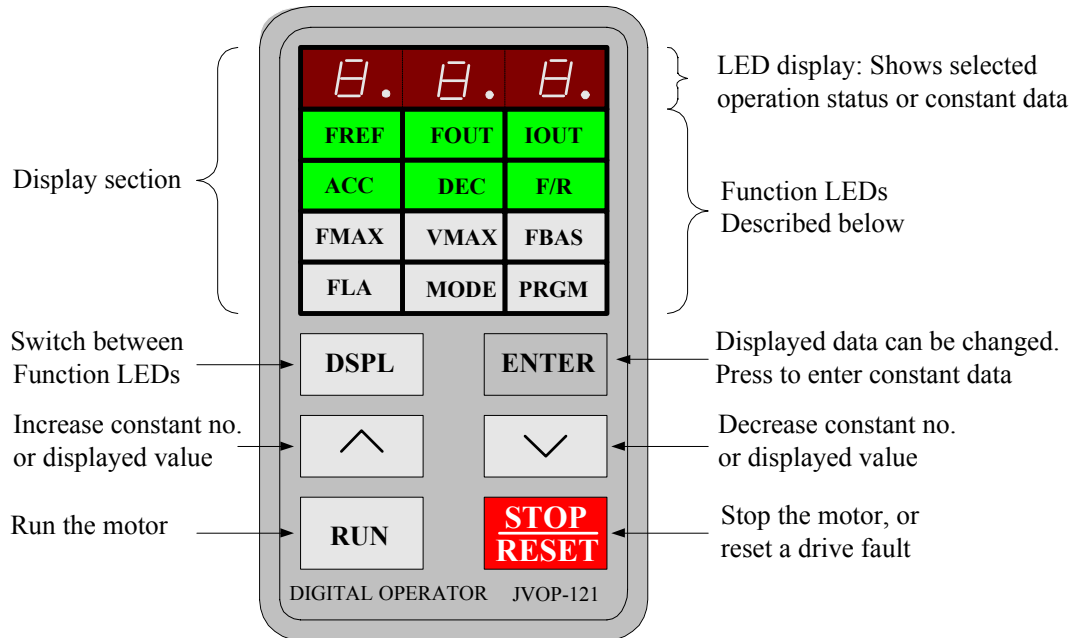

LED Description

By pressing the **DSPL** key on the Digital Operator can step to each of the twelve function LEDs. While the drive is running only the first six (GREEN) function LEDs can be selected.

- FREF** — Frequency Reference Setting [constant **n11**]: Sets the frequency Hz or (speed).
- FOUT** — Output Frequency Monitor: Displays the output frequency (monitor only).
- IOUT** — Output current Monitor: Displays the output current (monitor only)
- ACC** — Acceleration Time [constant **n20**]: Sets the time (seconds) it will take the drive to accelerate the motor from standstill to maximum output frequency.
- DEC** — Deceleration Time [constant **n21**]: Sets the time (seconds) it will take the drive to decelerate the motor from the maximum output frequency to standstill.

- F/R** — FWD/REV Run Selection [constant **n04**]: Sets the rotation direction of the motor when a run command is given by the Digital Operator
- FMAX** —. Maximum Output Frequency {constant **n24**}: Sets the maximum output frequency (Hz) of the drive.
- VMAX** —. Maximum Voltage {constant **n25**}: Sets the maximum voltage (V) that can be output from the drive.
- FBAS** —. Maximum Voltage Output Frequency {constant **n26**}: Sets the frequency at which the maximum output voltage level is reached.
- FLA** —. Electronic Thermal Reference Current [constant **n31**]: Sets the motor overload.
- MODE** —. Operation Mode Selection [constant **no2**]: Selects the operation from the Digital Operator or Control Circuit Terminals.
- PRGM** —. Constant Programming: Selects or reads constant data using constant numbers (nxx). Constant data is displayed by pressing the **ENTER** key, and can be changed by pressing \wedge or \vee keys. Any change can be saved by again pressing the **ENTER** key. Pressing the **DSPL** key exits from programming mode.